

## Manual Highway Tape Applicator (MHTA-2)

Also Available in 18" (MHTA-18-2)

### Description

The Manual Highway Tape Applicator (MHTA-1) is a simple two-wheeled, push-type device for applying 3M™ Sta-mark™ and Scotch-Lane™ pavement marking tapes. (See Figure 1).

The device is specifically designed to apply pavement markings pre-coated with pressure sensitive adhesive during and immediately following asphalt resurfacing operations. It can also be used to apply pressure sensitive adhesive coated markings on existing surfaces or temporary markings used in construction work zones.

The 160 lb. aluminum and steel applicator can be partially disassembled by removing the handle and pointer, for easy transport.



Figure 1

### Product Width and Spacing

Two 4" (100 mm) lines can be applied at the same time, with 4" (100 mm) spacing between the lines. Combinations of solid and skip lines may be applied simultaneously.

Single lines of widths up to 12" (300 mm) wide can also be installed as a solid line or skip lines. The MHTA can be used to apply all Stamark and Scotch-Lane pavement marking tapes at maximum standard roll lengths.

Note: If special ordering tape, the maximum roll diameter can not exceed 20" (50.8 cm) if the material is to be applied with a Manual Highway Tape Applicator.

### Operation

The tape applicator can be operated by one person. The following application rates are based on asphalt paver speed of 25 – 50 ft./min. and a walking speed of 100 ft./min.

10:30 Skip	750 ft./hr.
15:25 Skip	1125 ft./hr.
Solid Line	1500 ft./hr.
Solid/Skip (NPZ)	2500 ft./hr.
Double Solid	3000 ft./hr.
Overall Average	1000 ft./hr.

Note: The application rates shown are intended as guidelines and may vary with project conditions.

### Procedure For Threading Tape

Load the tape and thread over the 2-inch (5.08 cm) diameter roll, adhesive side up. (Figure 2) Feed the tape through the CLAMP to the CUTTER PLATE. Adjust the GUIDE BARS at the sides of the tape rolls to hold them securely in position.

**Caution:** Do not activate the cutting knife with the foot pedal while threading tape!

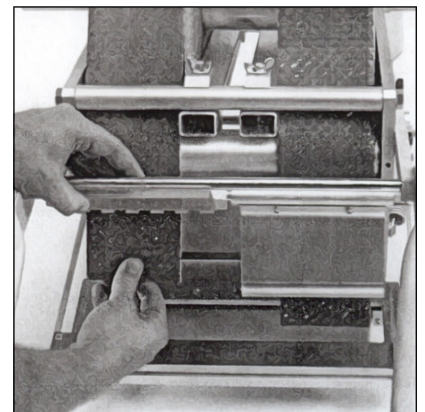

Figure 2

## Application Techniques

(Refer to Diagram A)

### Pre-marking for Skip Lines:

Using 200-250 ft. (60-70 m) of light rope, chain or thin wire cable for a guide line, mark the skip sequence on the chain to be followed. Example: A Sash Chain marked to the proper sequence with 1-inch (2.54 cm) spiral key rings.

Example: For a 10 ft (3 m) skip line and a 30 ft. (9 m) space (10-30 sequence):

1. Mark point (A), the beginning of the first skip line, about 8 feet (2.44 m) from the beginning of the chain. (The extra 8 feet of chain helps to line up the applicator.)
2. Measure 10 ft. (3 m) and mark point (B), the end of the skip line.
3. Measure 30 ft (9 m) and mark point (A), the beginning of the next skip line.
4. Repeat steps 2 and 3 throughout the remaining length of the guideline so that the last mark is a point (A).

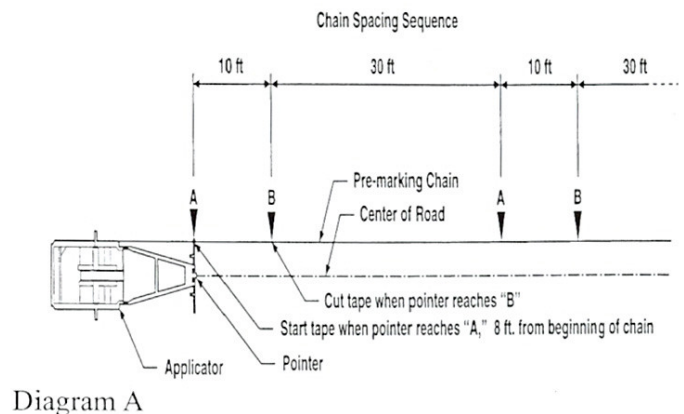

## Tape Application

1. Determine where the first skip or long line starts by measuring from the last existing skip or reference mark and the side of the road. Offset the pre-marked chain at least 12 inches (30 cm) from the center of where the new markings will be applied.
2. Lay the guideline out and adjust the pointer to the side of the applicator. Position the applicator even with the pre-marking chain and position the pointer to the side as shown.
3. Position both hands in the center of the applicator handles when moving the clamp handle forward to aid in keeping the applicator moving in a straight line. (See Figure 3). Slowly move the clamp handle forward while moving the applicator forward at about the same speed. After tape application has begun, immediately release the clamp handle to allow the tape to move freely. For skip line application, as the tape applicator is moved forward, start the pavement marking each time the **pointer** passes over "A," and cut the pavement marking each time the **pointer** passes over "B."
4. When the last mark on the guide line is reached, start the next pavement marking, stop the machine and again lay the guide line out in front of the pointer.



Figure 3

## Tape Cutting

Bring the applicator to a complete stop and back up ½ inch (1.25 cm) before cutting the tape. Release the foot pedal slowly. Do not attempt to cut the tape while moving. Cutting the tape in motion will stretch and tear the tape, causing the next line to start off center.

When cutting a single line or both lines of a double line, depress either the right or left foot pedal to the lowest position. (See Figure 4.)

When cutting a single line while applying a double line, depress the corresponding foot pedal. Depressing the foot pedal too far will cut both markings.

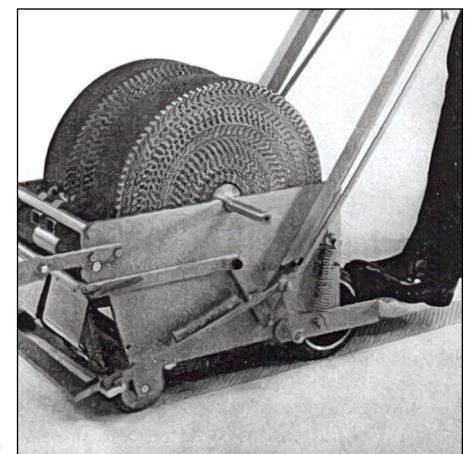

Figure 4

## Tamping

When inlaying pavement markings in a new asphalt concrete surfaces, tamp the markings during final compaction (finishing roller) of the mat. After application of markings on existing surfaces, tamp with the tape thoroughly with the Roller Tamper Cart (RTC-2) with a minimum 200 lb. (90 kg) load, or slowly (2-3 mph) drive over the tape three times with a vehicle tire. The vehicle **must be** equipped with a pointing device to aid in keeping the vehicle on the tape, making **three passes** forward over the tape. Use a vehicle tire on long line markings only. Do **not** attempt to tamp intersection markings with a vehicle tire. **Tamping is most important!**

When using the RTC-2 Roller Tamper Cart with 200 lbs. (90 kg) of weight:

- Do not twist or turn the tamping device on the tape.
- Make three passes back and forth over each part of the tape.
- When tamping symbols, start in the center and work to the outside edges.
- Make sure all edges are firmly adhered.
- Open road to traffic as soon as **tamping is complete**.

## Maintenance

### Keep All Fasteners Tight

**Lubrication:** The pivot points and sliding areas should be kept lubricated with light oil.

**Cleaning:** The rubber application roller wheels and cutting mechanism must be kept clean. Mineral spirits, fuel oil or any other light oil cleaners may be used on the wheels and knives. Solvents may be used occasionally for difficult cleaning problems. A spray bottle of cleaner is useful to

prevent asphalt buildup on the wheels and adhesive buildup on the knives during operation.

**Caution:** Do not use solvents or petroleum products on the silicone application roller when working on new, hot asphalt surfaces. A paint scraper or putty knife should be used to clean the asphalt buildup from the scraper bar. To prevent asphalt buildup around the roller, additional clearance can be provided by loosening the scraper mounting screws and sliding the scraper back. Tighten the screws.

## Adjustments

The **SCRAPER BAR**, which is preadjusted by the manufacturer to prevent excess materials from accumulating on the application roller, should be periodically checked for wear and rotated if necessary. The cutter bar should be adjusted to 1/16" (.16 cm) away from the rubber roller.

The **KNIVES** are preadjusted by the manufacturer to slide across each other with a minimum of friction in a scissors action. Adjustment is needed when foil construction tapes are not cleanly cut. Either the **STATIONARY KNIFE** or the **SLIDING KNIFE** may be adjusted. (See Figure 5.) To adjust the stationary knife, loosen the mounting screws slightly. Turn the set screws to bring the cutting edge down, and retighten the mounting screws. The same procedure is followed to adjust the sliding knife. Each knife has two cutting edges. The knives may be removed and new cutting edges exposed. The knives may be sharpened after the cutting edges are dull.

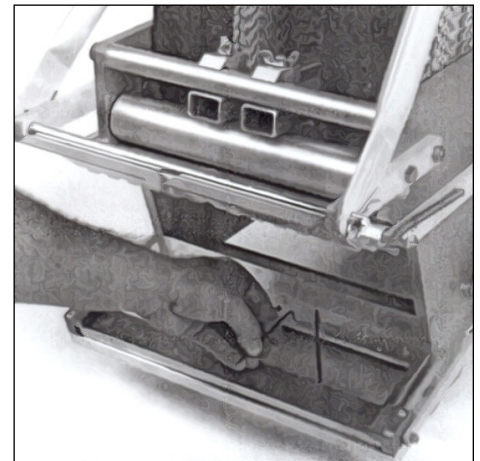

Figure 5

## Troubleshooting

**Tape Does Not Advance:** If the clamp springs have been overly stretched, there will not be enough tension to advance the tape. The springs should then be replaced. Thin foil tapes may strike the cutting bar during application if cut under tension. To prevent this problem, pull the applicator back 1-2 inches (2.54-5.08 cm) before cutting.

**Tape Does Not Cut:** The tape will not cut cleanly if cutting is done while the applicator is in motion. If the knife edges are dull or out of alignment, the knives should be sharpened and adjusted. (See Adjustments.) Clean adhesive build up from the knives. (See Maintenance.)

**Replacement Parts**

The following is a complete listing of available replacement parts for the 12 inch (30.5 cm) wide Manual Highway Tape Applicator (MHTA-1). When ordering, please note the MH-x” number in the right column of the alphabetical listing. (See Table 1.)

A complete description for all parts included for each order entry number is provided in the Spare Parts List. Some parts are not available separately, take time to find the proper order number that contains all the parts needed. All assemblies come complete with the title item (in bold) and hardware listed. (See Table 2.)

**Table 1**

**Alphabetical Listing of Items**

See Table 2 for a complete listing.

Aluminum Roll Assembly	MH-2
Axle	MH-23
Bar Guide Assembly	MH-4
Clamp Assembly	MH-8
Clamp Pivot Shaft	MH-7
Clamp Spring (small)	MH-9
Clamp Spring (large)	MH-10
Cutter Bar	MH-6
Cutter Blade	MH-5
Cutter Plate	MH-21
Cutter Spring Assembly	MH-14
Guide Clamp (front)	MH-12
Guide Clamp (rear)	MH-13
Pointer	MH-25
Pointer Assembly	MH-22
Pointer Clamp Assembly	MH-18
Side Frame Connecting Rod	MH-24
Silicone Rubber Roll	MH-3
Stock Roll Shaft	MH-1
Stop Clamp	MH-20
Swivel Caster Assembly	MH-16
Tape Guide	MH-11
Wheel Assembly	MH-17

Note: After locating the proper replacement part, check the following table to see a complete listing of hardware included with each assembly.

**Table 2**

**Spare Parts List**

<u>Code</u>	<u>Description</u>
<b>MH-1</b>	<b>Stock Roll Shaft</b>
<b>MH-2</b>	<b>Aluminum Roll Assembly</b> (1) 2 inch Diameter Roll (2) Flanged Bearing-Oilite No. FF-1014 (2) Set Screw-Hex. Soc., Cup Point, 1/4-20 x 3/8
<b>MH-3</b>	<b>Silicone Rubber Covered Roll Assembly</b> (1) 4 inch Diameter Roll (2) Flanged Bearing-Oilite No. FF-1014 (2) Set Screw-Hex. Soc., Cup Point, 1/4-20 x 3/8
<b>*MH-4</b>	<b>Bar Guide Assembly</b> (2) Screw, Soc. Hd. Cap, Stl., Zinc Plt. 1/4-20 x 1-1/4 (1) Screw, Soc. Hd. Cap, Stl., Zinc Plt. Loc-Wel, 1/4-20 x 5/8
<b>MH-5</b>	<b>Cutting Blade</b> (7) Cap Screw-Hex. Soc., Stl., Zinc Plt. #10-24 x 3/8 Lg. Loc-Wel (6) Set Screw-Hex. Soc., Cup Point Zinc Plt., #10-24 x 3/8 Lg. Loc-Wel
<b>MH-6</b>	<b>Cutting Bar</b>
<b>MH-7</b>	<b>Clamp Pivot Shaft Assembly</b> (2) Screw, Soc. HD. Cap, Loc-Wel, Stl., Zinc Plt., 1/4-20 x 3/4 Lg.
<b>MH-8</b>	<b>Clamp Assembly</b> (1) Tape Guide (2) Cap Screw-Hex. Soc., Stl., Zinc Plt. #10-24 x 5/16 Lg. Loc-Wel
<b>*MH-9</b>	<b>Clamp Spring (small) Assembly</b> (2) Lee Spring #Le-037D9-MW (4) Screw, Bottom Hd. Cap, Stl., Zinc Plt., 1/4-20 x 3/4 Lg. (2) Screw, Soc. Hd. Cap, Stl., Zinc Plt., #10-24 x 1/2 Lg. (1) Blue Line Print
<b>*MH-10</b>	<b>Clamp Spring (large) Assembly</b> (1) Screw, Hex Hd. Cap., Stl., Zinc Plt., 1/4-20 x 7/8 Lg. (1) Nut, Hex, Stl., Zinc Plt., 1/4-20
<b>*MH-11</b>	<b>Tape Guide</b>
<b>*MH-12</b>	<b>Guide Clamp (front) Assembly</b> (1) Wing Nut, Stl., Zinc Plt., 3/8-16
<b>*MH-13</b>	<b>Guide Clamp (rear) Assembly</b> (1) Wing Nut, Stl., Zinc Plt., 3/8-16
<b>*MH-14</b>	<b>Cutter Spring Assembly</b> (2) Screw, Hex Hd. Cap, Stl., Sinc Plt., 1/4-20 x 3/4 Lg. (Nut, Hex, Stl., Zinc Plt., 1/4-20

**\* Note:** Universal Spare Parts (MHTA-1, MHTA-16, MHTA-18)

**Replacement Part Numbers  
Contact Century Tool at  
(763) 428-2168**

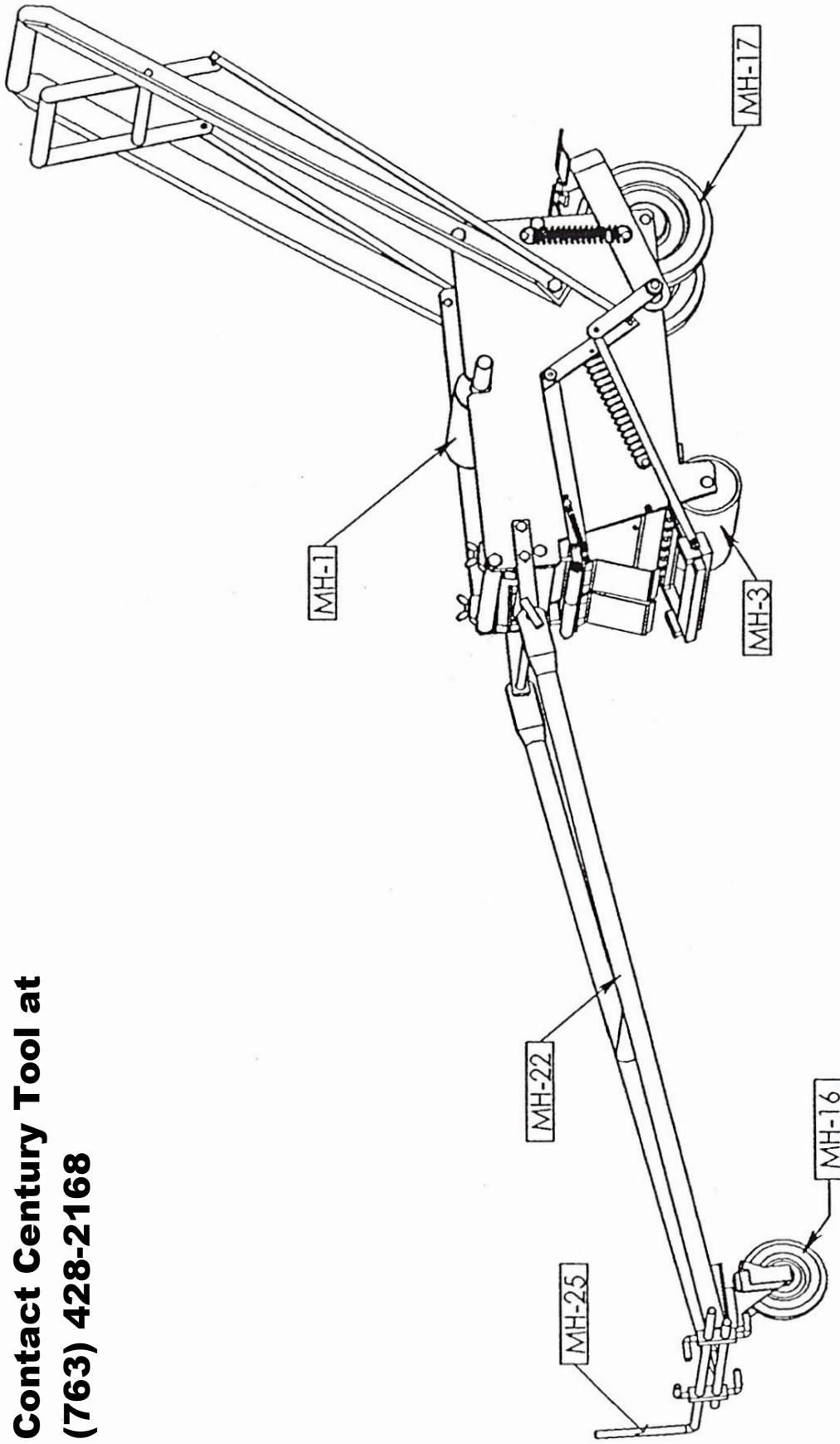

CENTURY TOOL INC.  
TAPE APPLICATOR  
SHEET 1 OF 3

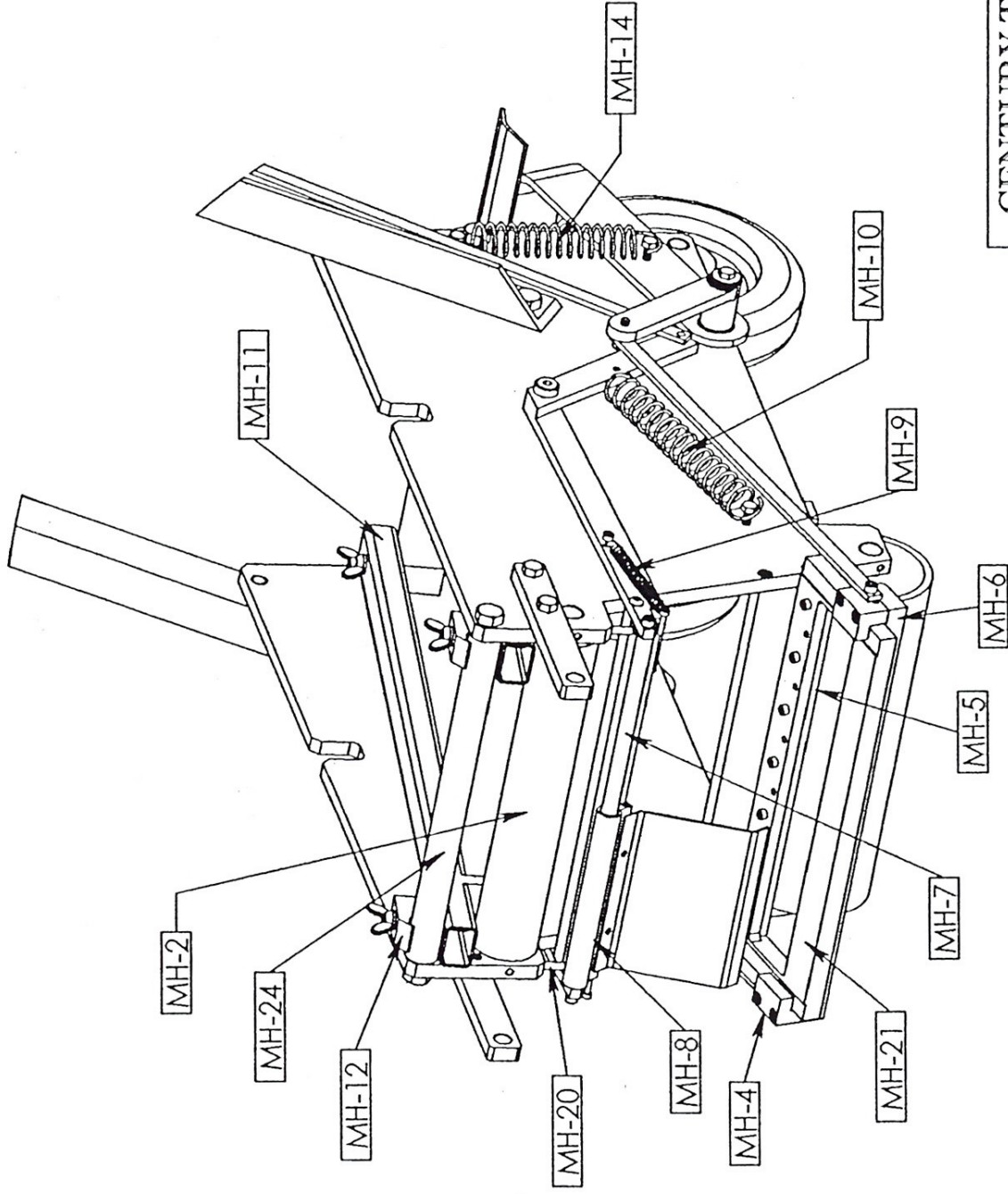

CENTURY TOOL INC.

TAPE APPLICATOR

SHEET 2 OF 3

**Replacement Part Numbers  
Contact Century Tool at  
(763) 428-2168**

**Replacement Part Numbers  
Contact Century Tool at  
(763) 428-2168**

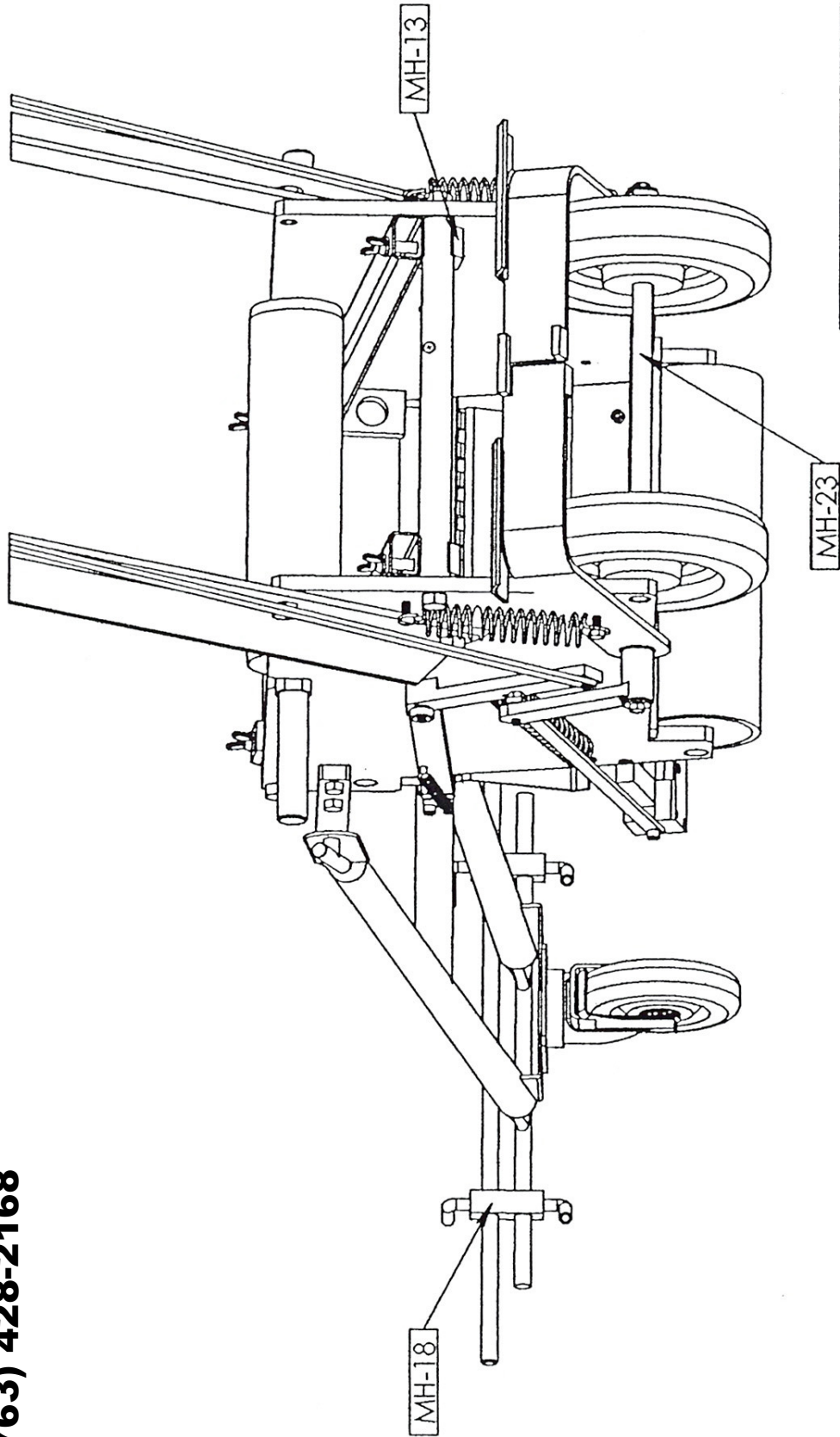

CENTURY TOOL INC.

TAPE APPLICATOR

SHEET 3 OF 3